

SilkyEvCam BothView C-mount model Specification

Product name : BothView C-mount

Model name : EvB4AS-C / EvB4BS-C

Rev.2.0.1

CenturyArks Co., Ltd.

Approval	Responsible person
Y. Oka	Y. Kimura

Contents

Revision History	2
General description and application	2
Functions and Features	2
USE RESTRICTION NOTICE	3
Use Restrictions	3
Design for Safety	4
Export Control	4
No License Implied	4
Governing Law	4
Other Applicable Terms and Conditions	4
1 Summary of Specifications	5
1.1. Table 1 List of Specifications	5
1.2. Table 2 List of USB pin description	6
1.3. Table 3 List of IX Connector pin (Synchronization signals) description (event-based camera)	6
1.4. Transmittance characteristics of beamsplitter	7
1.5. Requirements	8
1.6. Notes on writing to firmware (event-based camera)	8
2 Operating Temperature	9
3 Operating Condition	9
4 Block Diagram (Event camera)	9
5 Power Structure (Event camera)	10
6 Dimensions	11
7 Notes on Handling and Assembly	12
7.1. Prevention of Electrostatic Discharge (ESD)	12
7.2. Notes on storage and operating environments	12
8 Packing specification	12

Revision History

Revision	Content	Date
Rev.1.0.0	Official Release	2024/11/20
Rev.1.0.1	Change the description of the USB cables in the specifications table.	2025/06/04
Rev.2.0.0	Added descriptions of internal wiring, IX connector, and synchronization.	2025/10/02
Rev.2.0.1	Corrected the link address.	2026/04/01

General description and application

SilkyEvCam BothView is a product that combines an event sensor and a frame sensor and passes light divided by a beamsplitter through both sensors to enable simultaneous acquisition of event and frame images. Since the images are captured by a single eye, identical images can be captured, eliminating the parallax that is inevitable when cameras are placed in parallel. In addition, data can be synchronized by sending timing signals from the frame sensor side to the event sensor side.

This document describes BothView C mount model product specifications.

Please refer to the information site provided by SONY for the specifications of the each sensor (IMX636/IMX392) and related applications. Please refer to the information site provided by Allied Vision for the specifications of the frame camera (Alvium1800 U-240c) and related applications.

See the CenturyArks website for the latest information.

Functions and Features

- ◆ SilkyEvCam HD (CenturyArks Co., Ltd.) (for event-based camera)
 - IMX636(HD) Sony Event-based vision sensor
 - 1/2.5" 1280x720px
 - Wide Dynamic Range (86dB or more)
 - Contrast Detection (CD) events only
 - Event time-stamping with microsecond (μ s) precision
- ◆ Alvium1800 U-240c bareboard (Allied Vision) (for frame camera)
 - IMX392 Sony color CMOS image sensor
 - 1/2.3" 1936x1216px
 - Global shutter
 - For details on frame camera, refer to [the datasheet for the product](#).
- ◆ Optical axis alignment: within ± 2 pixels at the center of the sensors
- ◆ Power supply and data exchange with standard USB 3.0 interface (both cameras)
- ◆ Input power: 5V (from USB connector) (both cameras)
- ◆ Incident light is split by a beamsplitter.
- ◆ Two models are available, differing in the spectral ratio of the beamsplitter. (T90:R10 / T50:R50)
- ◆ Effective resolution: max 1800x1012pixel (when two images acquired by both cameras are overlaid and combined.)
- ◆ Camera housing with C-mount (*)
- ◆ Size approximately 80mmx55mmx37mm (w/o Lens)
- ◆ Consumption current: 700mA (typical)
- ◆ PROPHESEE support SDK named Metavision® SDK
- ◆ Allied Vision support SDK named Vimba X SDK

[Accessories]

- ◆ Lens: VY1214 (YAKUMO) f=12mm, F1.4 - F16.0
- ◆ USB 3.0 Type-C cable with lock screw (1.2m)
- ◆ USB 3.0 Type-micro B cable with lock screw (1.2m)
- ◆ Soft mobile case

(*) Some C-mount lenses have a rear protrusion behind the C-mount screw. Due to this product has a beamsplitter just behind the lens, so be sure to use a lens with a length of 6 mm or less from the flange, including this protrusion.

Device Configuration

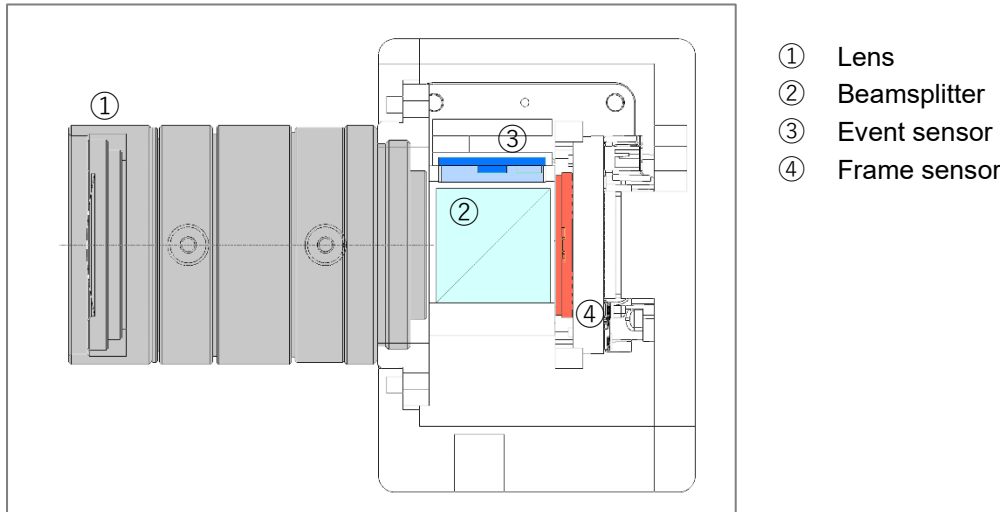

Referenced Documents

No.	Document Title
1	Metavision SDK® Docs (PROPHESSEE website)
2	Vimba X SDK Docs (Allied Vision website)

USE RESTRICTION NOTICE

This USE RESTRICTION NOTICE ("Notice") is for customers who are considering or currently using the event sensor camera products ("Products") set forth in this specifications book. CenturyArks Corporation ("CA") may, at any time, modify this Notice which will be available to you in the latest specifications book for the Products. You should abide by the latest version of this Notice. distributor has its own use restriction notice on the Products, such a use restriction notice will additionally apply between you and the distributor. You should consult a sales representative of the distributor of on such a use restriction notice when you consider using the Products.

Use Restrictions

- The Products are intended for incorporation into such general electronic equipment as office products, communication products, measurement products, and home electronics products in accordance with the terms and conditions set forth in this specifications book and otherwise notified by CA from time to time.
- You should not use the Products for critical applications which may pose a life- or injury-threatening risk or are highly likely to cause significant property damage in the event of failure of the Products. You should consult your sales representative beforehand when you consider using the Products for such critical applications. In addition, you should not use the Products in weapon or military equipment.
- CA disclaims and does not assume any liability and damages arising out of misuse, improper use, modification, use of the Products for the above-mentioned critical applications, weapon and military equipment, or any deviation from the requirements set forth in this specifications book.

- CA is not responsible for any direct or indirect damage such as loss of stored data or damage to equipment caused by failure or use of this product.
- When installing and using this product, be sure to follow the warnings and precautions issued by the PC manufacturer and peripheral device manufacturer.
- This products and the application provided by CA do not guarantee the operation for all Computers.

Design for Safety

- CA is making continuous efforts to further improve the quality and reliability of the Products; however, failure of a certain percentage of the Products is inevitable. Therefore, you should take sufficient care to ensure the safe design of your products such as component redundancy, anti-conflagration features, and features to prevent mis-operation in order to avoid accidents resulting in injury or death, fire or other social damage as a result of such failure.

Export Control

- If the Products are controlled items under the export control laws or regulations of various countries, approval may be required for the export of the Products under the said laws or regulations. You should be responsible for compliance with the said laws or regulations.

No License Implied

- The technical information shown in this specifications book is for your reference purposes only. The availability of this specifications book shall not be construed as giving any indication that CA and its licensors will license any intellectual property rights in such information by any implication or otherwise. CA will not assume responsibility for any problems in connection with your use of such information or for any infringement of third-party rights due to the same. It is therefore your sole legal and financial responsibility to resolve any such problems and infringement.

Governing Law

- This Notice shall be governed by and construed in accordance with the laws of Japan, without reference to principles of conflict of laws or choice of laws. All controversies and disputes arising out of or relating to this Notice shall be submitted to the exclusive jurisdiction of the Tokyo District Court in Japan as the court of first instance.

Other Applicable Terms and Conditions

- The terms and conditions in the CA additional specifications, which will be made available to you when you order the Products, shall also be applicable to your use of the Products as well as to this specifications book. You should review those terms and conditions when you consider purchasing and/or using the Products.

1 Summary of Specifications

1.1. Table 1 List of Specifications

BothView C mount model Specifications				
Event Based Vision sensor	Model	IMX636 (Sony)		
	Image size	Type 1/2.5" (Diagonal 7.14mm)		
	Module effective pixels	1280 (H) x 720 (V)		
	Pixel size	4.86um x 4.86um		
	Shutter type	NA		
	Wide Dynamic Range	>86dB		
	Latency	100 μsec or under @1klux		
	Readout throughput	40M events/s as default (depend on the PC spec.)		
Frame Based Vision sensor	Model	IMX392 (Sony)		
	Image size	Type 1/2.3" (Diagonal 7.9mm)		
	Module effective pixels	1936 (H) x 1216 (V)		
	Pixel size	3.45um x 3.45um		
	Shutter type	Global shutter		
	Frame rate	60fps as default (depend on the PC spec.)		
Optical axis	alignment	within ±2 pixels at the center of the sensors		
Beamsplitter	Type	Unpolarizing		
	Ration	EvB4AS-C EvB4BS-C	T90:R10 (Frame camera: 90%, Event camera: 10%) T50:R50 (Frame camera: 50%, Event camera: 50%)	
Output	Interface (Event camera)	USB 3.0 (Type-C connector)		
	Interface (Frame camera)	USB 3.0 (Type-micro B connector)		
	Interface (Sync/Trigger) (Event camera)	IX Series Connector (IX80G-B-10P: HIROSE) (Plug:IX30G-B-10S-CV(7.0) IX31G-B-10S-CV(7.0))		
Camera	Power supply	USB Power (VBUS) x2	5.0 V	
	Lens Mount type	C mount (*)		
	Operating temperature	T operation	+5 ~ +35 °C	
	Storage temperature	T storage	-20 ~ +80 °C	
	Current consumption	700mA (typical)		
	Dimensions (w/o Lens)	approximately 80mm (W) x 55mm (H) x 37mm (D)		
	Weight (w/ Lens)	approximately 330g		
	Cables	USB3.0 Type A - Type C (w/ rock screw) Cable length 1.2m		
		USB3.0 Type A - Type-micro B (3.0) (w/ rock screw) Cable length 1.2m		
	PID/VID (Hex) (Event camera)	Vendor ID: 31F7	Product ID: 0003	
	Raw Formats (Event camera)	EVT3		
	Resolution	max 1800 x 1012pixel (Effective resolution when two images acquired by both cameras are overlaid and combined.)		
	Lens	Model	VY1214 (YAKUMO)	
Focal length		12mm		
F value		F1.4 – F16.0		
Angle of view		33.1deg (D) for 1/2.5" type		
Focus range		0.15m to infinity		
Size / Weight		Φ31mm x 37mm / 70g		
Others	SDK support by PROPHESSEE	Metavision® SDK		
	SDK support by Allied Vision	Vimba X SDK		

(*) Some C-mount lenses have a rear protrusion behind the C-mount screw. Due to this product has a beamsplitter just behind the lens, so be sure to use a lens with a length of 6 mm or less from the flange, including this protrusion.

1.2. Table 2 List of USB pin description

USB3.0 Type C

Pin No.	A1	A2	A3	A4	A5	A6	A7	A8	A9	A10	A11	A12
Signal A	GND	TX1+	TX1-	VBUS	CC1	D+	D-	SBU1	VBUS	RX2-	RX2+	GND
Signal B	GND	RX1+	RX1-	VBUS	SBU2	D-	D+	CC2	VBUS	TX2-	TX2+	GND
Pin No	B12	B11	B10	B9	B8	B7	B6	B5	B4	B3	B2	B1

USB3.0 Type micro B

Pin No.	1	2	3	4	5	6	7	8	9	10
Signal A	VBUS	D-	D+	ID	GND	SSTX-	SSTX+	GND	SSRX-	SSRX+

1.3. Table 3 List of IX Connector pin (Synchronization signals) description (event-based camera)

The IX connector is connected to the frame camera via internal wiring.

Pin No.	Signal	Pin No.	Signal
1	TRIGGER_OUT/SYNC_OUT_P +3.3V	6	TRIG_IN_N -opto-coupled (Internally connected to the frame camera)
2	SYNC_OUT_N	7	(Internally connected to the frame camera)
3	SYNC_IN_P -opto-coupled	8	(Internally connected to the frame camera)
4	SYNC_IN_N -opto-coupled	9	(Internally connected to the frame camera)
5	TRIG_IN_P -opto-coupled (Internally connected to the frame camera)	10	No use

In BothView, the frame camera and event camera are internally connected as shown in the figure below. This internal wiring can be used to inner sync and multi-device sync.

- Inner sync: Synchronization between frame camera and event camera within a single BothView unit.
- Multi-device sync: Synchronization by connecting two BothViews or BothView–SilkyEvCam VGA/HD devices.

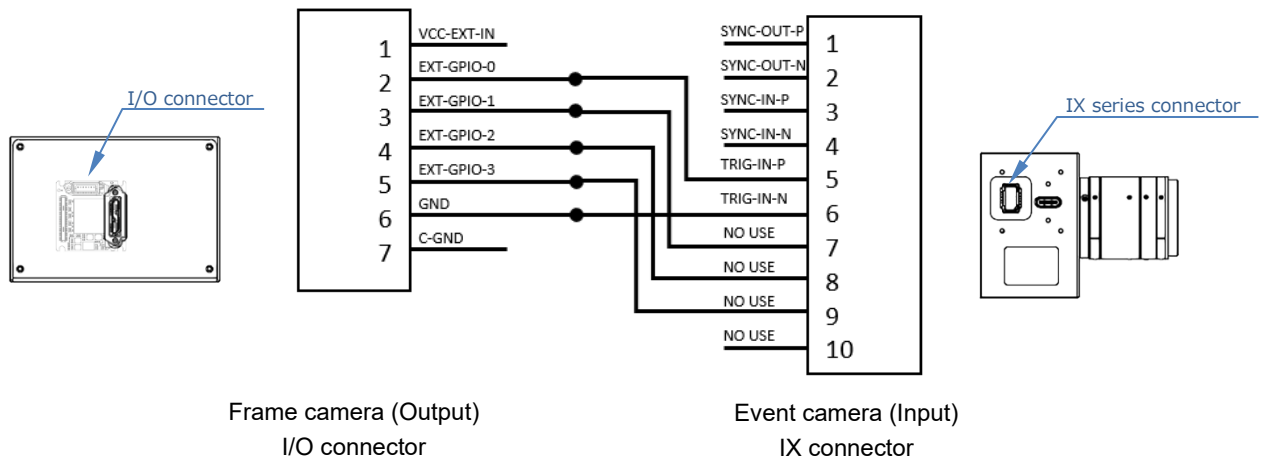

During inner sync, the trigger signal coming from the frame camera is recorded as an external trigger event in the raw data (EVT3 format) of the event camera. (For details on frame camera, refer to the datasheet for the product.)

BothView also allows synchronization between BothViews or between BothView and SilkyEvCam VGA/HD. Connected cameras become master and slave, with BothView always being the master. (A dedicated synchronization cable (maximum length 3m) is required for multi-device sync. Please contact us if you require a cable longer than 3m.)

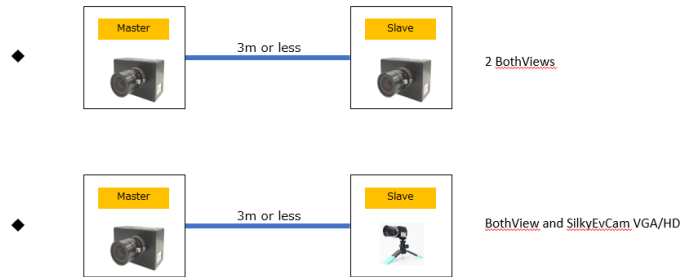

Reference for frame camera (Source)

- [Alvium USB Cameras documentation](#)
 - [Trigger IO overview](#)

Reference for event camera (Source)

- [SilkyEvCam HD Specification](#)
 - [Timing Interfaces](#)

1.4. Transmittance characteristics of beamsplitter

- Unpolarizing beamsplitter (T90:R10)

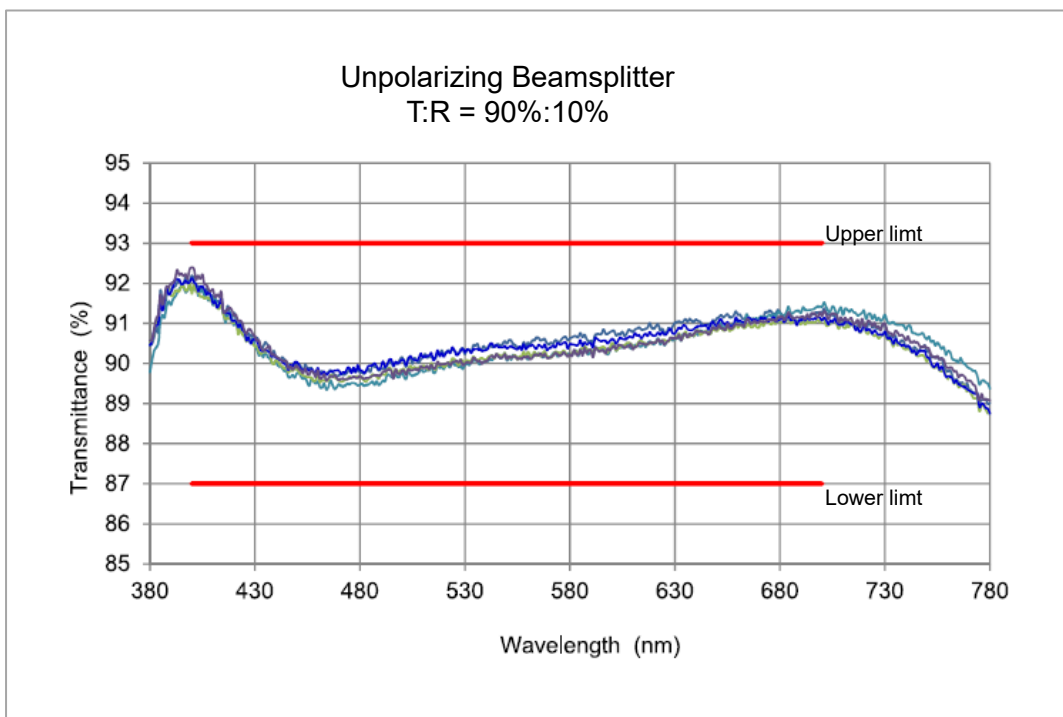

Source: YAKUMO

- Unpolarizing beamsplitter (T50:R50)

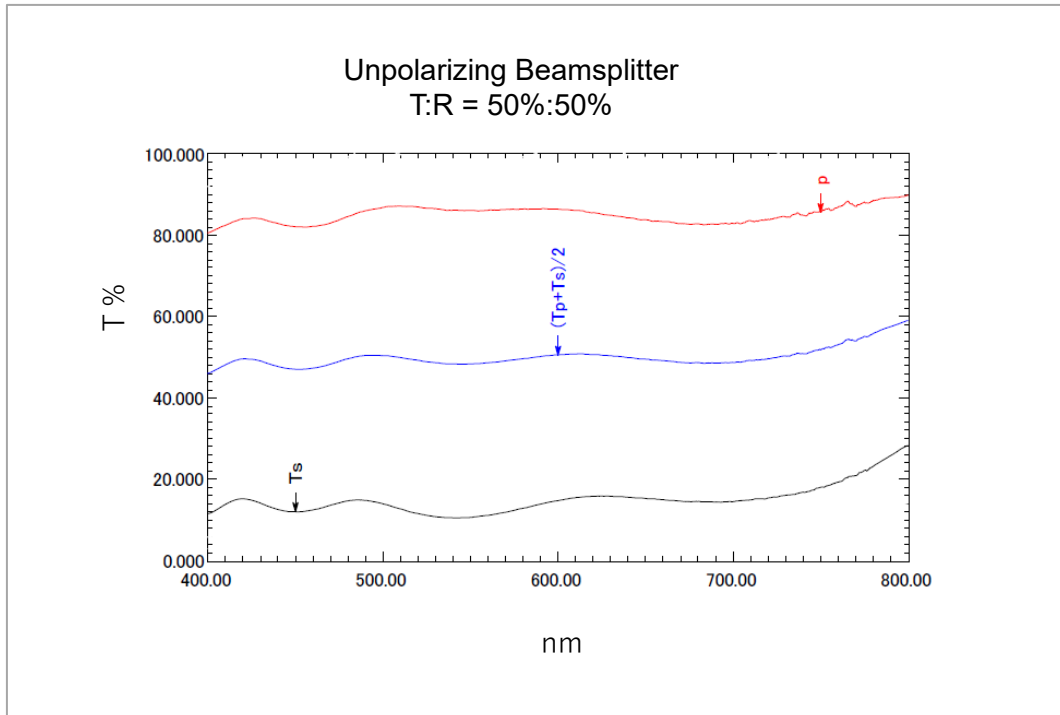

Source: Shibuya Optical Co., Ltd.

1.5. Requirements

The following requirements have to be met to use BothView on a computer.

Software requirements:

- Please refer to the latest software (Metavision® SDK) manual.
- Please refer to the latest software (Vimba X SDK) manual.

Installation requirements:

- Administrator rights (sudo account)
- Internet access (to install dependencies)

Physical Interfaces

BothView has two interfaces:

- USB 3.0 connector: for event-based camera (data and power supply)
- USB 3.0 connector: for frame camera (data and power supply)

1.6. Notes on writing to firmware (event-based camera)

Basically, no firmware change is required on the user side.

If an update is required, we will notify you via our website or other means.

2 Operating Temperature

Temperature Specifications

Item	Conditions	Specification	Unit
Operating temperature	Image should be output.	+5 ~ +35	°C
Storage temperature		-20 ~ +80	°C
Operating humidity range	no condensation	+80%RH or under	%RH

3 Operating Condition

Input Voltage	5V±0.25V (from USB connector)
---------------	-------------------------------

4 Block Diagram (Event camera)

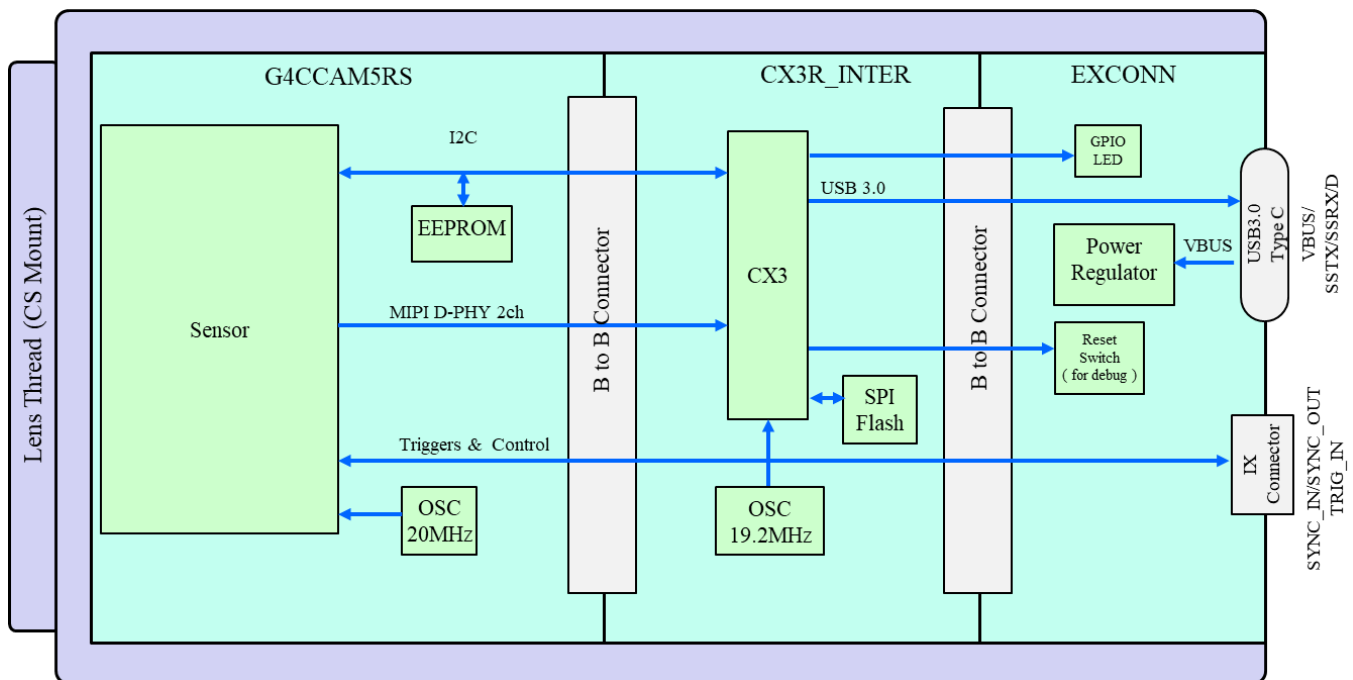

For details on frame camera, refer to the datasheet for the product.

5 Power Structure (Event camera)

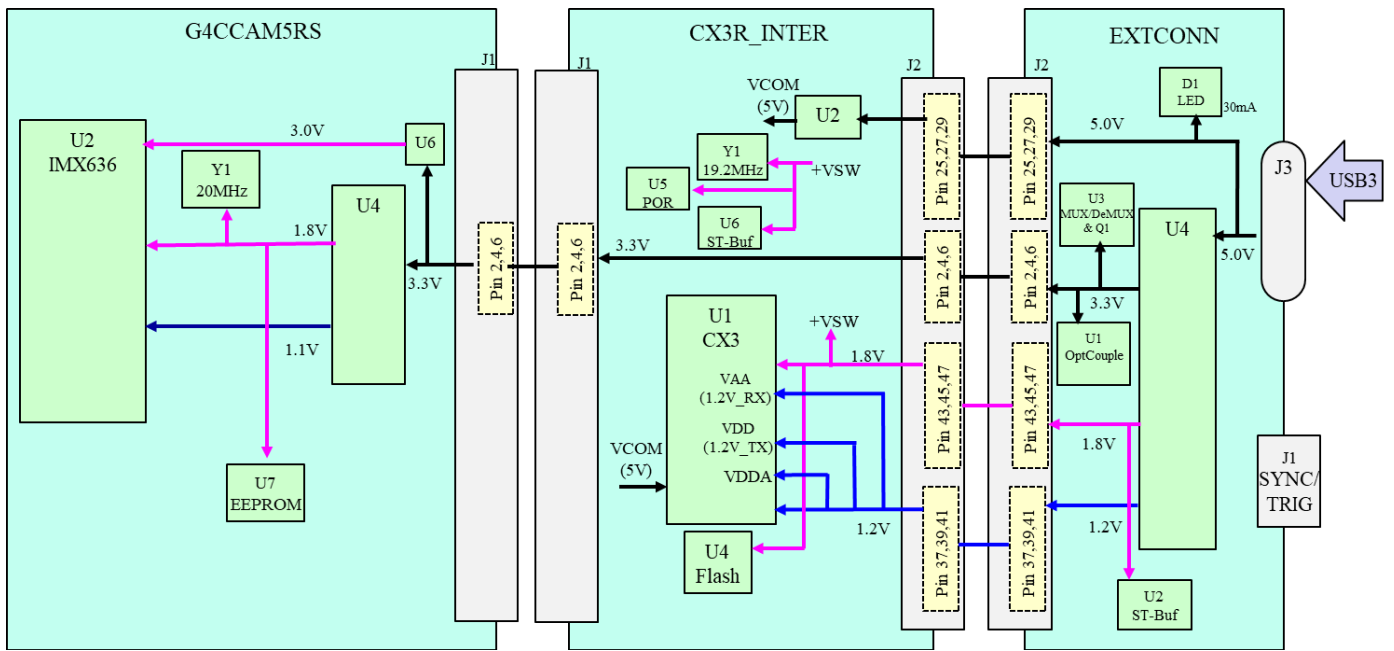

For details on frame camera, refer to the datasheet for the product.

6 Dimensions

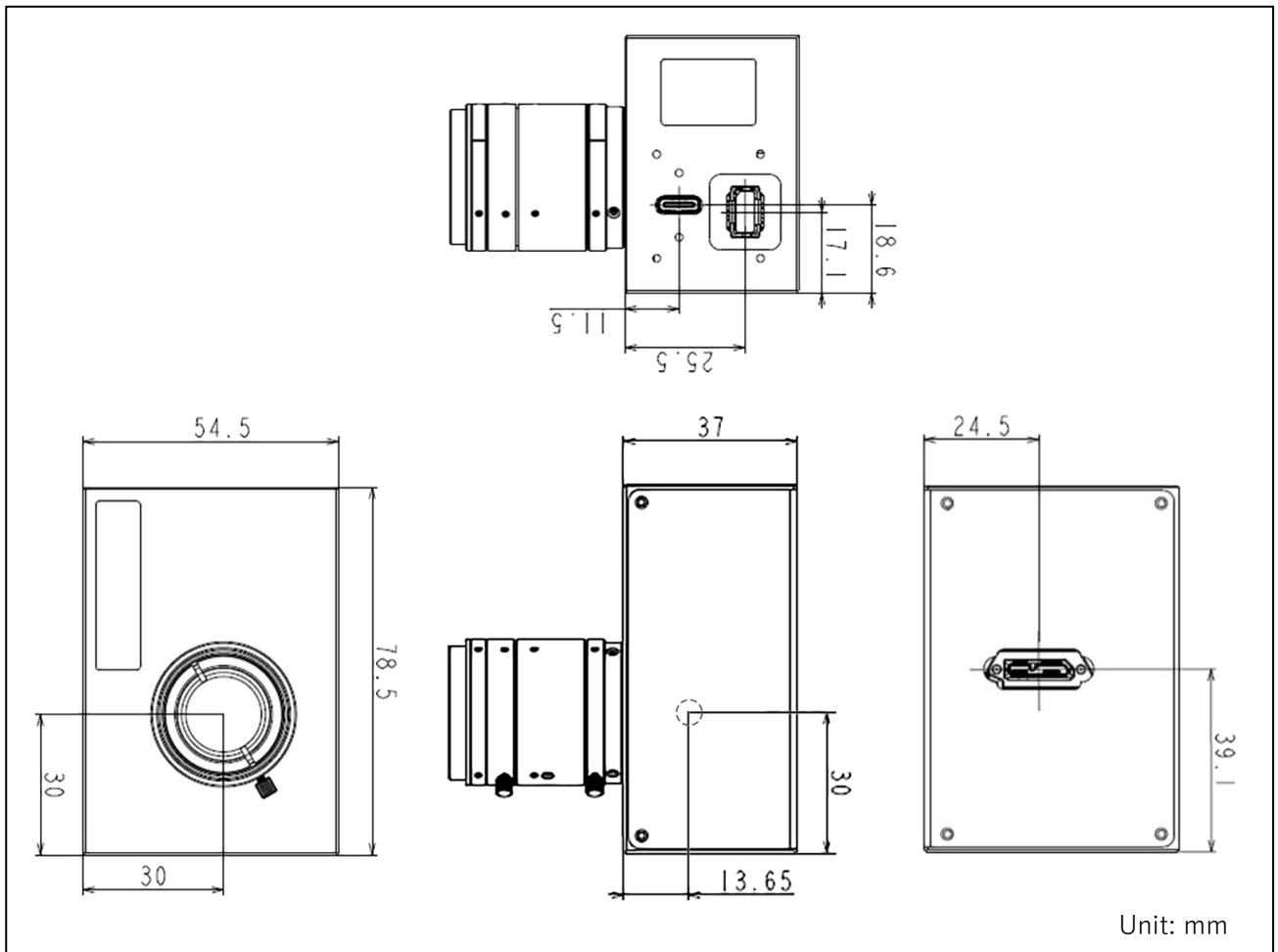
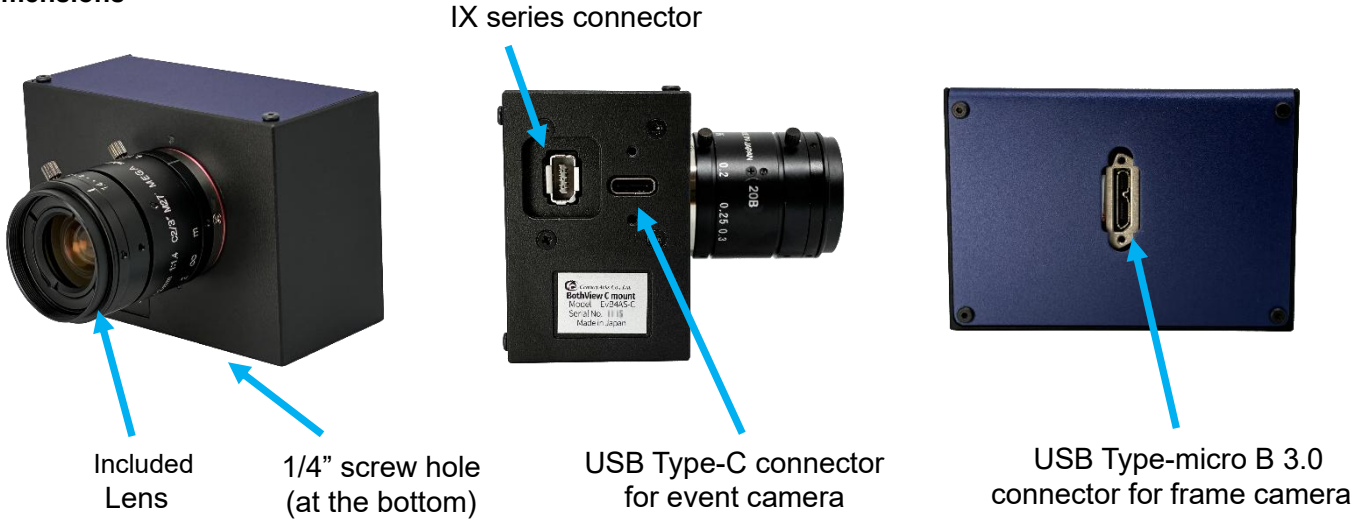

7 Notes on Handling and Assembly

When using this product, ensure safe design by heeding the following precautions.

7.1. Prevention of Electrostatic Discharge (ESD)

Image sensors and other ICs can easily be damaged by static discharge. When handling these modules, take the following measures to prevent static discharge.

- (1) Either use non-chargeable gloves, clothes or material. Also use conductive shoes.
- (2) Use a wrist strap when handling directly.
- (3) Install grounded conductive mats on the floor and working table to prevent the generation of static electricity.
- (4) Ionized air is recommended for discharge when handling Event-based sensors.
- (5) For the shipment of camera, use bag treated for the prevention of static charges.

7.2. Notes on storage and operating environments

Do not store or use the camera modules in harsh environments with high temperatures, high humidity levels, and high concentrations of dust or in environments where condensation may form from moisture or dampness.

8 Packing specification

